

iPad – Turning On

1. Charge your iPad

If your iPad is not charged, you will need to charge it.

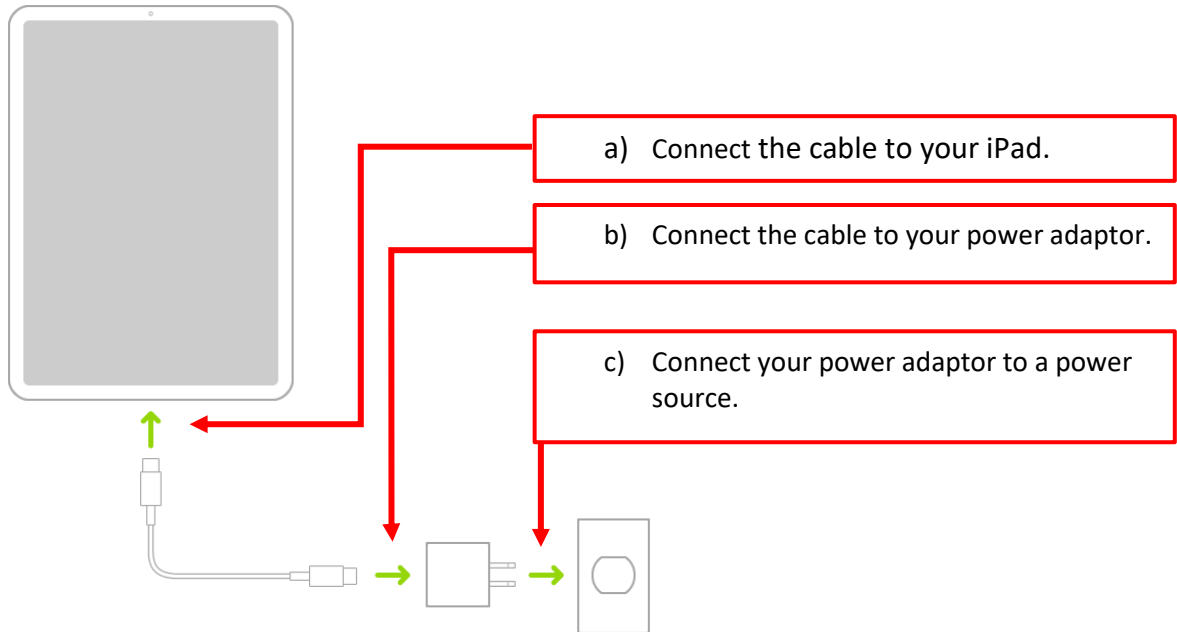

2. Turn on your iPad



a) **Press** the top (power) button to turn on your iPad.

If you are turning on your iPad for the first time, or your iPad had a flat battery before charging it, **press and hold** the top (power) button until the Apple logo appears.

If you are using your iPad for the first time, the screen will show the word 'Hello' in many languages.